

direct operated solenoid valves

coil 31 mm

general information	
ambient temperature	- 10°C to + 50°C
response time	10 - 20 ms
mounting	in any position
standard seal materials*	NBR, FPM, EPDM
dimensions	see page 2/2
coil data	see page 2/2
connector data	see page 2/2

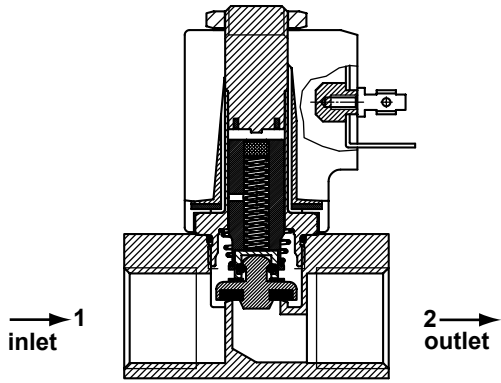

NC

\* other seal materials on request

function	symbol	orif. mm	*Kv	pressure range (bar)			nominal power		TABLE A main code
				min.	max. DC	max. AC	Watt DC	V.A. AC inr. hol.	
<b>2/2 normally closed (NC)</b> 									
		10.0	22.0	0	0.3	0.5	10	21.5	13.5

\*l/min. of water with ΔP of 1 bar

